

CATÁLOGO DE PERFILES DE ACRISTALAMIENTO I

GLAZING RUBBER PROFILES CATALOG I

MÁS DE 200 REFERENCIAS DE:

- PERFILES DE ACRISTALAMIENTO DE
DIMENSIONES INFERIORES A 30.1MM

EN MATERIALES EPDM, CR, NBR, SBR...



PERFILES DE ACRISTALAMIENTO

DIMENSIÓN MÁXIMA INFERIOR A 20 MM

243/A0	1393/A0	1414/A0
EPDM 60° Sh.A	EPDM 60° Sh.A	A CONSULTAR

1723/A0	3299/A0	5136/A0
EPDM 60° Sh.A	EPDM 60° Sh.A	EPDM 60° Sh.A

5154/A0	5297/A0	6675/A0
EPDM 60° Sh.A	EPDM 60° Sh.A	EPDM 60° Sh.A

7079/A0	7189/A0	7551/A0
CR 70° Sh.A	EPDM 60° Sh.A	EPDM 60° Sh.A

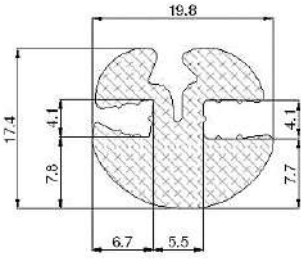
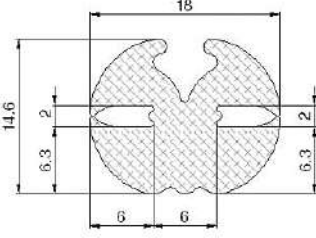
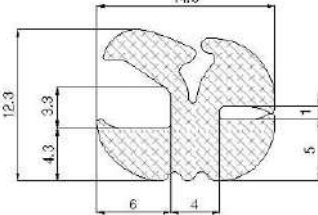
7730/A0	5642/A0	6464/A0
		
EPDM 60° Sh.A	EPDM 60° Sh.A	EPDM 60° Sh.A

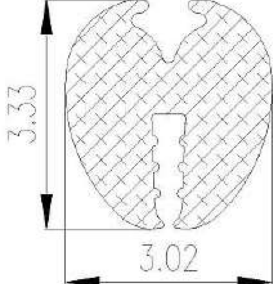
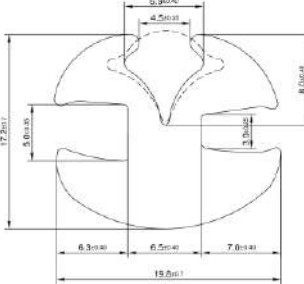
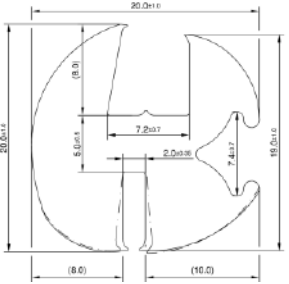
8246/A0	9333/A0	9437/A0
		
EPDM 60° Sh.A	NBR 70° Sh.A	EPDM 60° Sh.A

DIMENSIÓN MÁXIMA ENTRE 20.1MM Y 30MM

4/A0	5/A0	82/A0
EPDM 60° Sh.A	EPDM 80° Sh.A	EPDM 60° Sh.A

105/A0	139/A0	226/A0
EPDM 60° Sh.A	EPDM 60° Sh.A	EPDM 60° Sh.A

232/A0	242/A0	250/A0
EPDM 60° Sh.A	EPDM 60° Sh.A	EPDM 60° Sh.A

269/A0	270/A0	312/A0
EPDM 60° Sh.A	EPDM 60° Sh.A	EPDM 60° Sh.A

315/A0	382/A0	422/A0
EPDM 60° Sh.A	EPDM 60° Sh.A	EPDM 60° Sh.A

453/A0	464/A0	502/A0
EPDM 60° Sh.A CR 70° Sh.A	EPDM 60° Sh.A	EPDM 60° Sh.A

506/A0	523/A0	534/A0
EPDM 60° Sh.A	EPDM 60° Sh.A	EPDM 60° Sh.A

564/A0	573/A0	574/A0
EPDM 60° Sh.A NBR 70° Sh.A	EPDM 60° Sh.A	EPDM 60° Sh.A

611/A0	691/A0	696/A0
EPDM 60° Sh.A	EPDM 60° Sh.A	EPDM 60° Sh.A

709/A0	741/A0	774/A0
EPDM 60° Sh.A	EPDM 60° Sh.A	EPDM 60° Sh.A

877/A0	879/A0	909/A0
EPDM 60° Sh.A	EPDM 60° Sh.A	EPDM 60° Sh.A

911/A0	912/A0	979/A0
EPDM 60° Sh.A	EPDM 60° Sh.A	EPDM 60° Sh.A

1048/A0	1053/A0	1056/A0
A CONSULTAR	A CONSULTAR	EPDM 60° Sh.A

1066/A0	1125/A0	1189/A0
A CONSULTAR	EPDM 60° Sh.A	A CONSULTAR

1200/A0	1213/A0	1218/A0
EPDM 60° Sh.A	EPDM 60° Sh.A	A CONSULTAR

1227/A0	1275/A0	1276/A0
EPDM 60° Sh.A	CR 70° Sh.A	EPDM 70° Sh.A

1283/A0	1292/A0	1349/A0
A CONSULTAR	EPDM 70° Sh.A	A CONSULTAR

1352/A0	1356/A0	1404/A0
EPDM 60° Sh.A	EPDM 60° Sh.A	A CONSULTAR

1436/A0	1437/A0	1613/A0
EPDM 60° Sh.A	EPDM 60° Sh.A	A CONSULTAR

1666/A0	1755/A0	1832/A0
A CONSULTAR	EPDM 60° Sh.A	EPDM 60° Sh.A

1860/A0	1928/A0	1952/A0
EPDM 60° Sh.A	A CONSULTAR	EPDM 60° Sh.A

1961/A0	2034/A0	2039/A0
A CONSULTAR	A CONSULTAR	A CONSULTAR

2064/A0	2113/A0	2213/A0
A CONSULTAR	EPDM 60° Sh.A	A CONSULTAR

2269/A0	2280/A0	2306/A0
EPDM 60° Sh.A CR 70° Sh.A	A CONSULTAR	EPDM 60° Sh.A

2502/A0	2562/A0	2604/A0
EPDM 60° Sh.A	A CONSULTAR	EPDM 60° Sh.A

2647/A0	2743/A0	2749/A0
A CONSULTAR	EPDM 60° Sh.A	EPDM 60° Sh.A CR 70° Sh.A

2763/A0	2802/A0	2835/A0
EPDM 60° Sh.A	CR 70° Sh.A	EPDM 60° Sh.A

2908/A0	2909/A0	2910/A0
EPDM 60° Sh.A	EPDM 60° Sh.A CR 70° Sh.A	EPDM 60° Sh.A

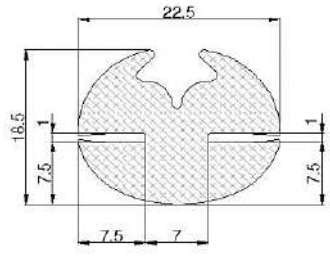
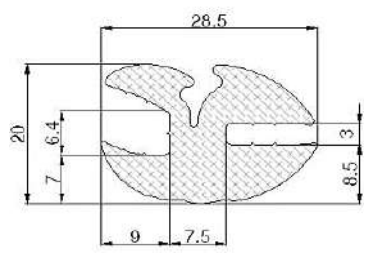
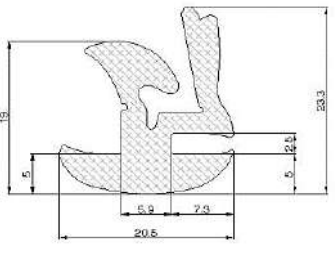
2911/A0	3012/A0	3044/A0
		
A CONSULTAR	A CONSULTAR	EPDM 60° Sh.A

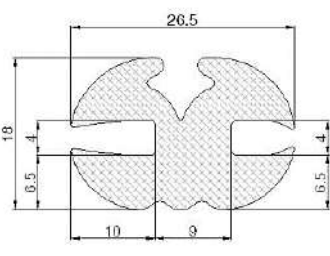
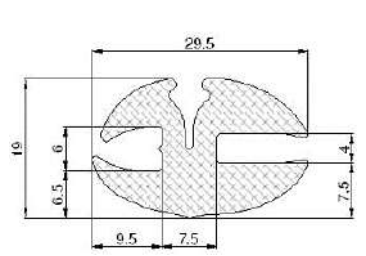
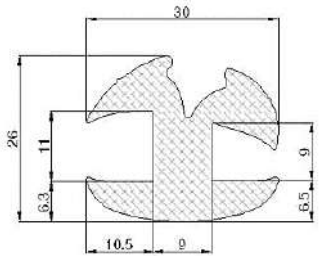
3250/A0	3251/A0	3319/A0
		
EPDM 60° Sh.A	EPDM 60° Sh.A	A CONSULTAR

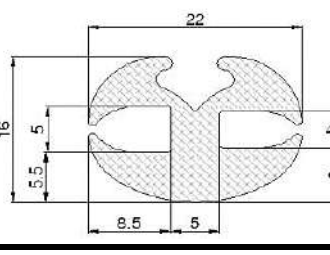
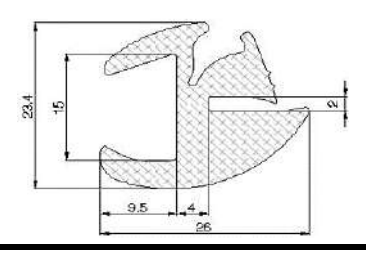
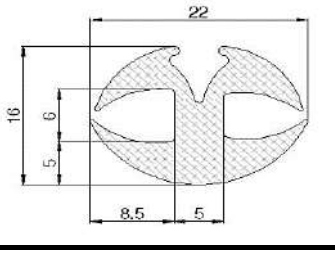
3322/A0	3326/A0	3329/A0
		
EPDM 60° Sh.A	A CONSULTAR	EPDM 60° Sh.A

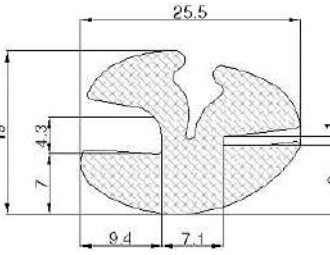
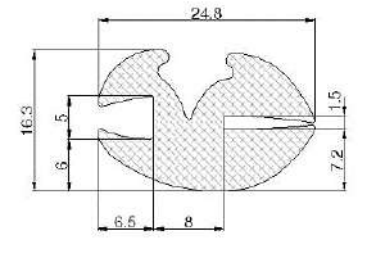
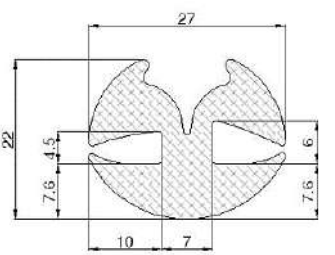
3340/A0	3547/A0	3562/A0
		
EPDM 70° Sh.A	EPDM 70° Sh.A	EPDM 60° Sh.A

3607/A0	4052/A0	4070/A0
EPDM 60° Sh.A	A CONSULTAR	EPDM 60° Sh.A

4186/A0	4194/A0	4197/A0
EPDM 60° Sh.A CR 70° Sh.A	EPDM 60° Sh.A	EPDM 60° Sh.A

4278/A0	4290/A0	4349/A0
A CONSULTAR	EPDM 70° Sh.A	EPDM 70° Sh.A

4395/A0	4422/A0	4439/A0
EPDM 70° Sh.A	EPDM 60° Sh.A	EPDM 70° Sh.A

4462/A0	4476/A0	4550/A0
EPDM 60° Sh.A	EPDM 60° Sh.A	EPDM 60° Sh.A

4556/A0	4613/A0	4727/A0
EPDM 60° Sh.A	EPDM 60° Sh.A CR 70° Sh.A	EPDM 60° Sh.A

4736/A0	4737/A0	4788/A0
EPDM 60° Sh.A	EPDM 60° Sh.A CR 70° Sh.A	EPDM 60° Sh.A

4789/A0	4828/A0	4857/A0
EPDM 60° Sh.A	EPDM 60° Sh.A	EPDM 60° Sh.A

4958/A0	4970/A0	4972/A0
EPDM 60° Sh.A	EPDM 60° Sh.A	EPDM 60° Sh.A NBR 70° Sh.A

4978/A0	5054/A0	5121/A0
EPDM 60° Sh.A	EPDM 60° Sh.A	EPDM 60° Sh.A

5145/A0	5160/A0	5181/A0
EPDM 60° Sh.A	EPDM 60° Sh.A	EPDM 60° Sh.A

5192/A0	5200/A0	5237/A0
EPDM 60° Sh.A CR 70° Sh.A	EPDM 70° Sh.A	EPDM 60° Sh.A

5240/A0	5260/A0	5261/A0
EPDM 70° Sh.A	EPDM 60° Sh.A CR 70° Sh.A	EPDM 60° Sh.A

5346/A0	5363/A0	5458/A0
EPDM 60° Sh.A	EPDM 60° Sh.A	EPDM 60° Sh.A CR 70° Sh.A

5511/A0	5543/A0	5554/A0
EPDM 60° Sh.A	EPDM 60° Sh.A EPDM 70° Sh.A CR 70° Sh.A	EPDM 60° Sh.A

5558/A0	5621/A0	5762/A0
EPDM 60° Sh.A CR 70° Sh.A	EPDM 60° Sh.A	EPDM 60° Sh.A CR 70° Sh.A

5776/A0	5782/A0	5801/A0
EPDM 60° Sh.A CR 70° Sh.A	EPDM 60° Sh.A	EPDM 60° Sh.A

5876/A0	5932/A0	5980/A0
EPDM 60° Sh.A	EPDM 60° Sh.A	CR 70° Sh.A

6173/A0	6184/A0	6234/A0
EPDM 60° Sh.A	EPDM 70° Sh.A	EPDM 60° Sh.A

6279/A0	6395/A0	6416/A0
EPDM 60° Sh.A	EPDM 60° Sh.A	EPDM 60° Sh.A

6422/A0	6467/A0	6599/A0
EPDM 60° Sh.A	EPDM 60° Sh.A CR 70° Sh.A	EPDM 60° Sh.A

6629/A0	6653/A0	6674/A0
EPDM 60° Sh.A	EPDM 60° Sh.A	EPDM 60° Sh.A

6704/A0	6770/A0	6829/A0
EPDM 60° Sh.A	EPDM 60° Sh.A	EPDM 60° Sh.A

6830/A0	6831/A0	6833/A0
EPDM 60° Sh.A	EPDM 60° Sh.A	EPDM 60° Sh.A

6942/A0	7184/A0	7186/A0
EPDM 60° Sh.A	EPDM 60° Sh.A	EPDM 60° Sh.A

7188/A0	7239/A0	7246/A0
EPDM 60° Sh.A	EPDM 60° Sh.A	EPDM 60° Sh.A

7247/A0	7248/A0	7281/A0
EPDM 60° Sh.A	EPDM 60° Sh.A	EPDM 60° Sh.A

7398/A0	7495/A0	7496/A0
EPDM 60° Sh.A	EPDM 60° Sh.A	EPDM 60° Sh.A

7572/A0	7606/A0	7739/A0
EPDM 60° Sh.A CR 70° Sh.A	EPDM 60° Sh.A	EPDM 60° Sh.A

7868/A0	7869/A0	7871/A0
SBR 70° Sh.A	SBR 70° Sh.A	SBR 70° Sh.A

7872/A0	7873/A0	7875/A0
SBR 70° Sh.A	SBR 70° Sh.A	SBR 70° Sh.A

7876/A0	7906/A0	8195/A0
SBR 70° Sh.A	EPDM 70° Sh.A	EPDM 60° Sh.A

8247/A0	8501/A0	8647/A0
CR 70° Sh.A	EPDM 70° Sh.A	EPDM 60° Sh.A

291/A0	423/A0	461/A0
EPDM 60° Sh.A	EPDM 60° Sh.A	EPDM 60° Sh.A

817/A0
A CONSULTAR

CONTAMOS CON MÁS GEOMETRÍAS QUE NO
HAN PODIDO SER INCLUIDAS EN EL CATÁLOGO.

PARA **OTRAS**
GEOMETRÍAS ESCRIBIR A

COMERCIAL@RIALS.ES

**CALLE PRIMAVERA 9, PARQUE
INDUSTRIAL “LAS MONJAS”, TORREJÓN
DE ARDOZ, 28850, COMUNIDAD DE
MADRID, ESPAÑA**

(Telf) +34 91 677 06 85

(FAX) +34 91 678 11 49

PUEDES SEGUIRNOS EN

 **Rials Extrusión Técnica S.L.**

MUCHO MÁS EN WWW.RIALS.ES