

CATÁLOGO DE PERFILES CON PVC

PERFILES DE GOMA ESPONJOSA (EPDM,
CR..) ADHERIDOS A UNA ESTRUCTURA DE
PVC CON INSERCIÓN METÁLICA

E-128-P

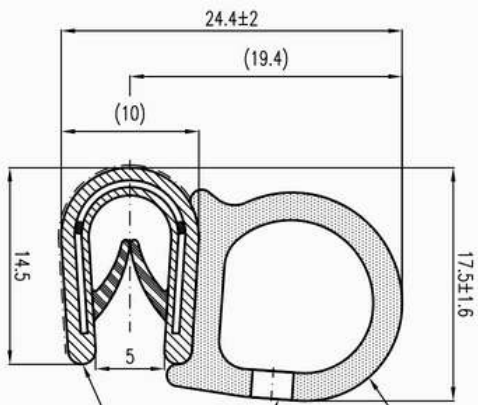

EPDM 0.60 GR/CM³

E-129-P

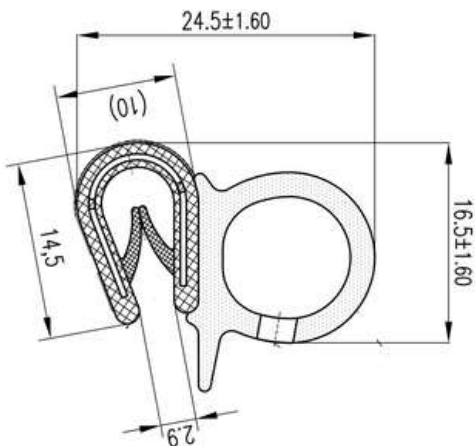

EPDM 0.60 GR/CM³

E-135-P

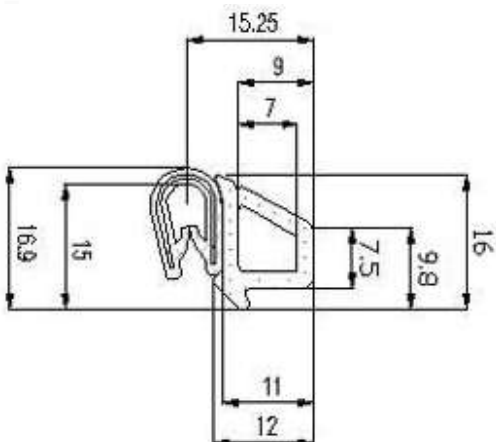

EPDM 0.60 GR/CM³

E-136-P

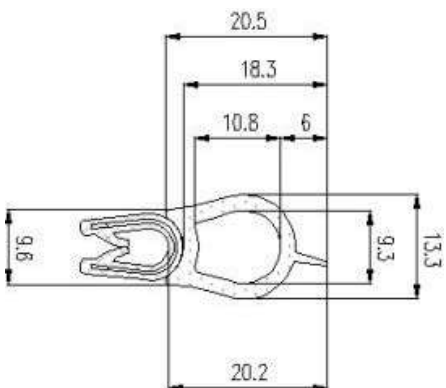

EPDM 0.60 GR/CM³

E-140-P

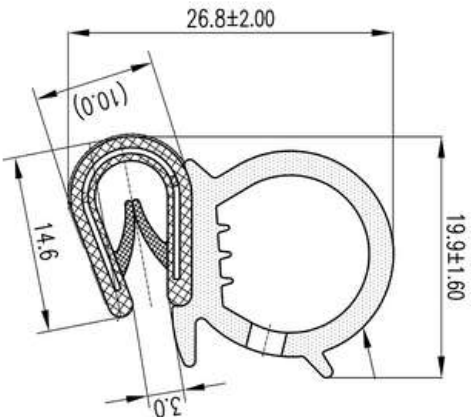

EPDM 0.60 GR/CM³

E-173-P

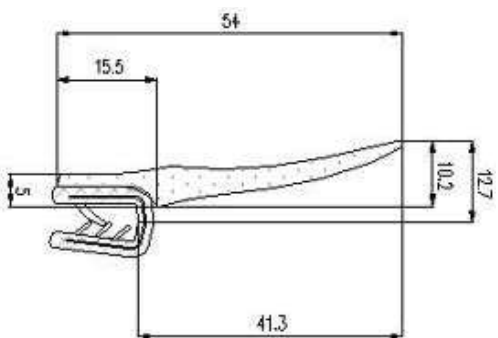

EPDM 0.60 GR/CM³

E-192-P

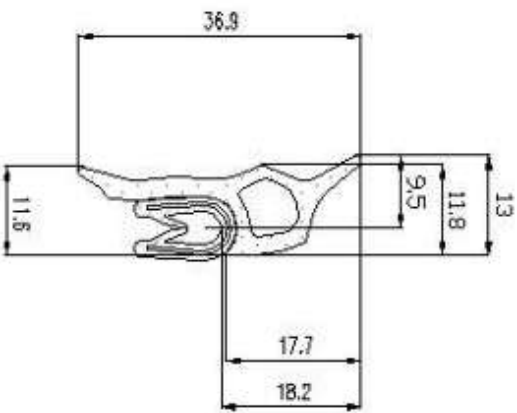

EPDM 0.60 GR/CM³

E-205-P

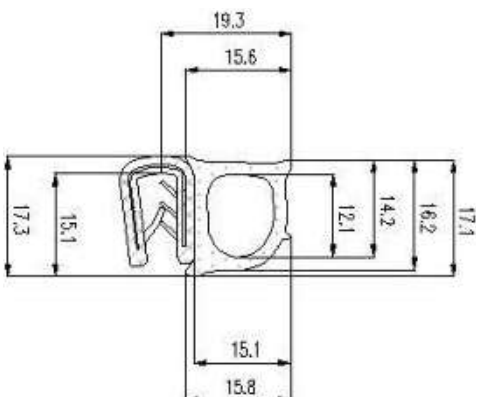

EPDM 0.60 GR/CM³

E-208-P

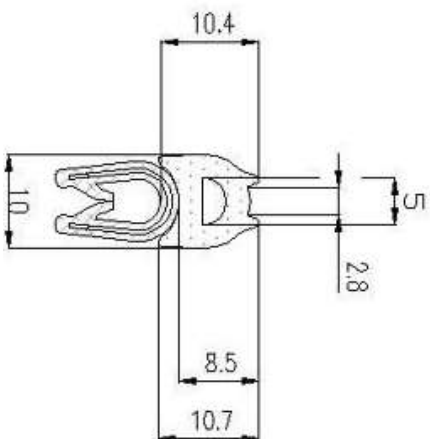

EPDM 0.60 GR/CM³

E-222-P

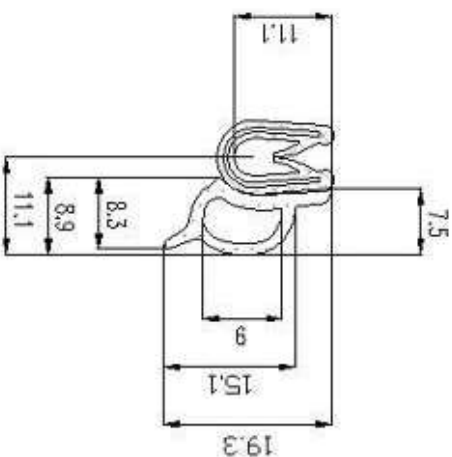

EPDM 0.60 GR/CM³

E-228-P

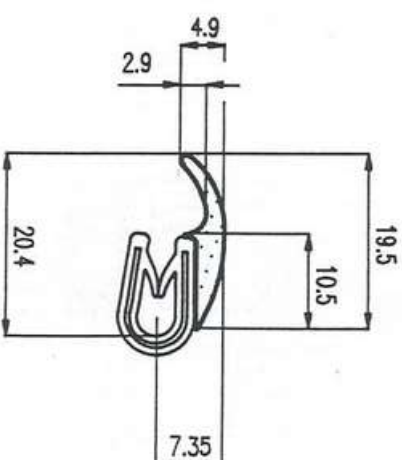

EPDM 0.60 GR/CM³

E-232-P

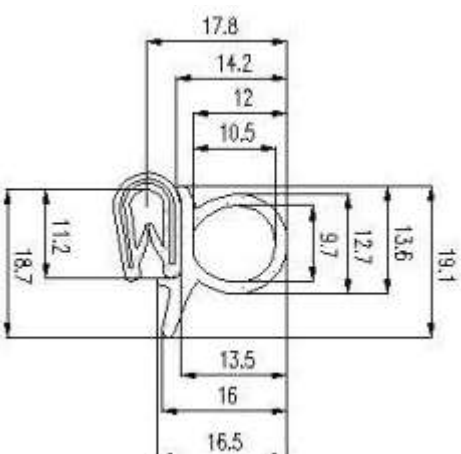

EPDM 0.60 GR/CM³

E-234-P

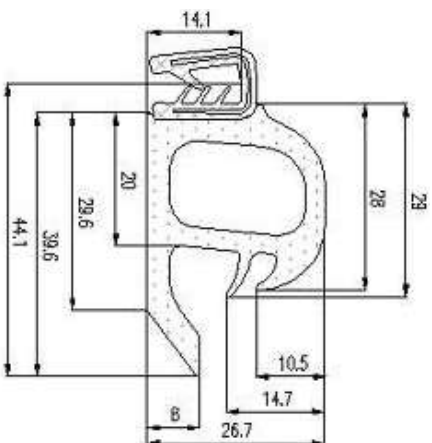

EPDM 0.60 GR/CM³

E-239-P

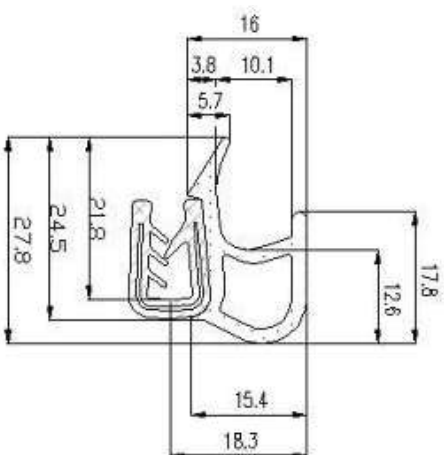

EPDM 0.60 GR/CM³

E-256-P

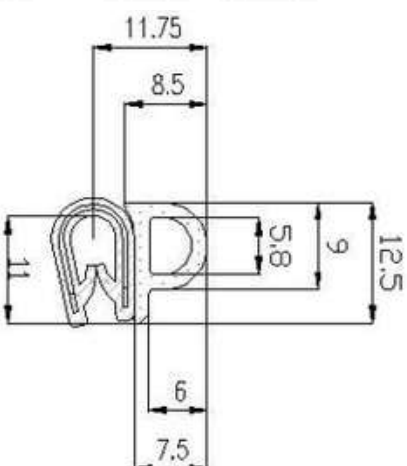

EPDM 0.60 GR/CM³

E-257-P

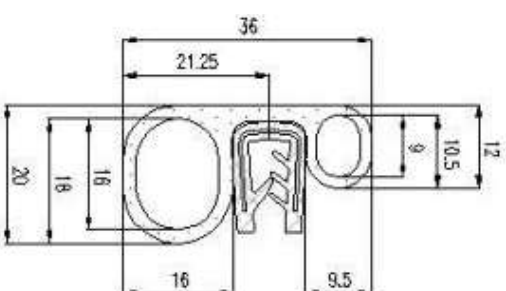

CR 0.60 GR/CM³

E-284-P

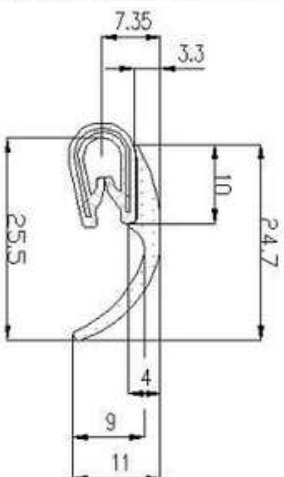

EPDM 0.60 GR/CM³

E-286-P

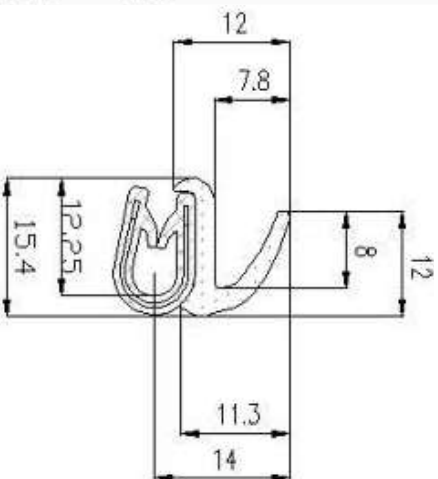

EPDM 0.60 GR/CM³

E-302-P

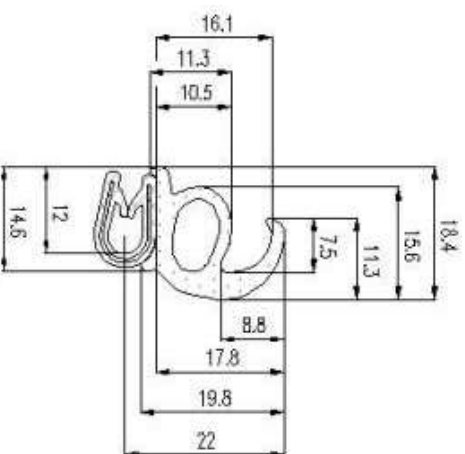

EPDM 0.60 GR/CM³

E-307-P

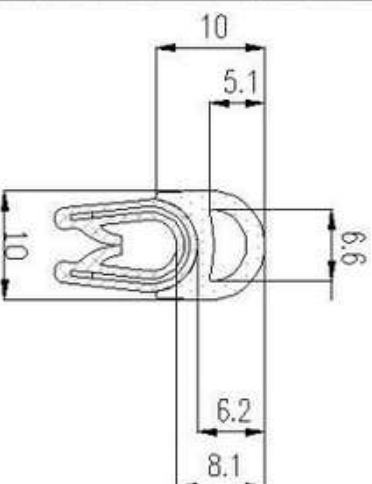

EPDM 0.60 GR/CM³

E-310-P

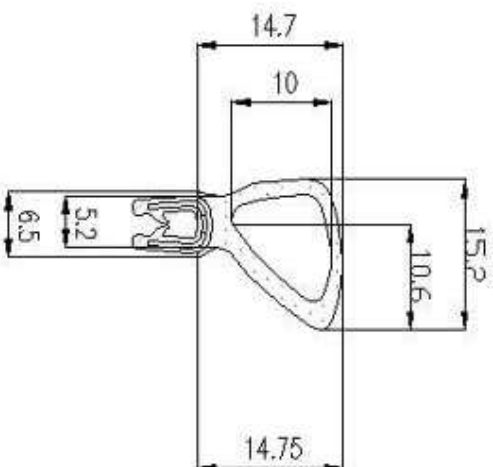

EPDM 0.60 GR/CM³

E-316-P

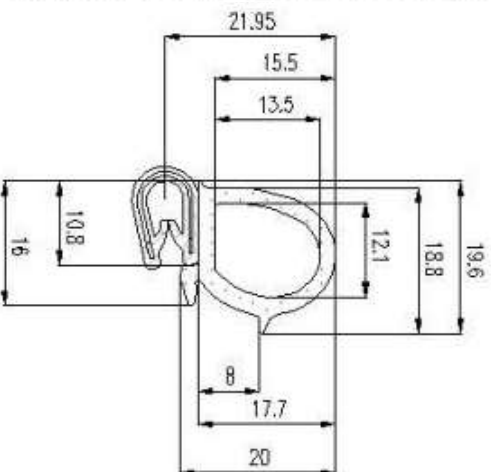

EPDM 0.60 GR/CM³

E-323-P

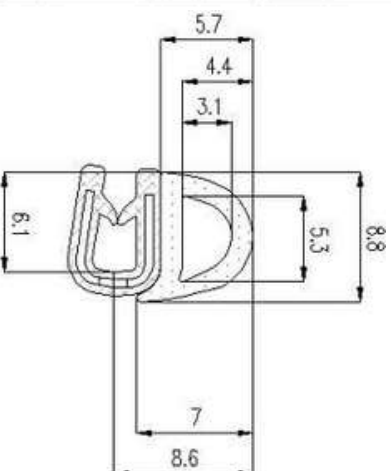

EPDM 0.60 GR/CM³

E-336-P

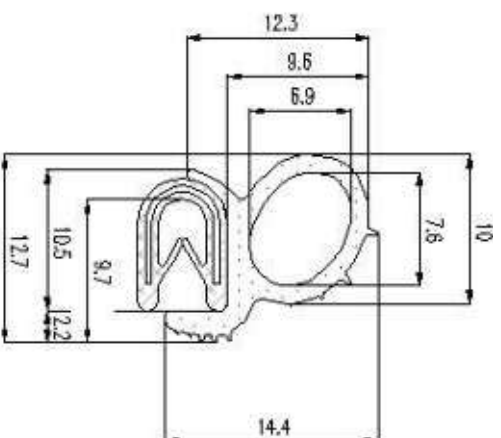

EPDM 0.60 GR/CM³

E-350-P

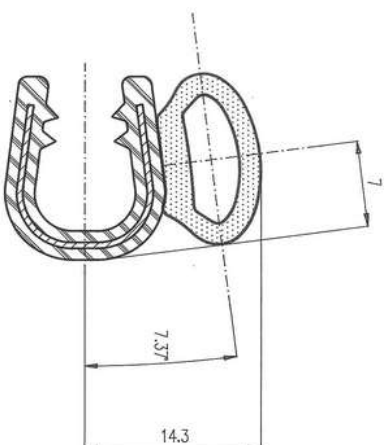

EPDM 0.60 GR/CM³

E-378-P

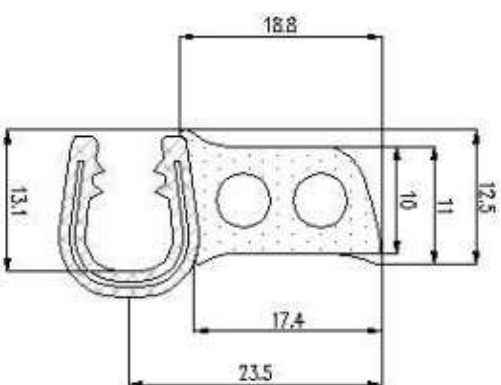

EPDM 0.60 GR/CM³

E-379-P

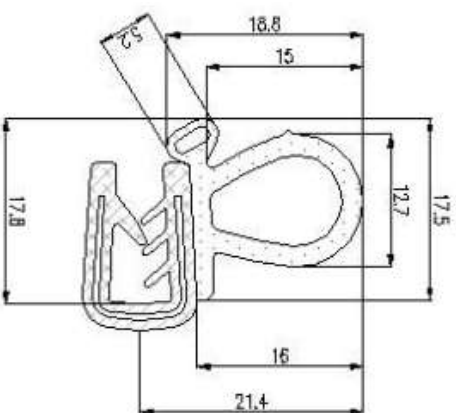

EPDM 0.60 GR/CM³



PÁGINA 4

E-383-P

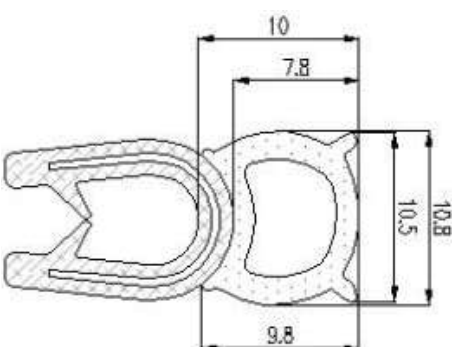

EPDM 0.60 GR/CM³

E-385-P

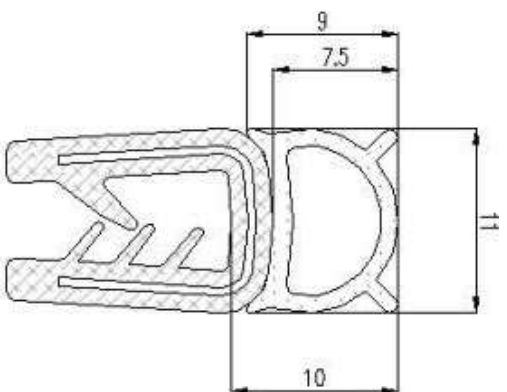

EPDM 0.40 GR/CM³

E-388-P

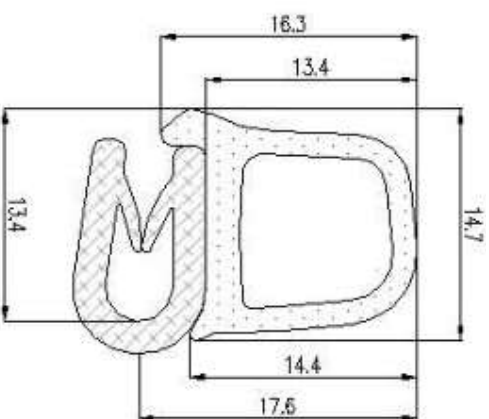

EPDM 0.60 GR/CM³

E-390-P

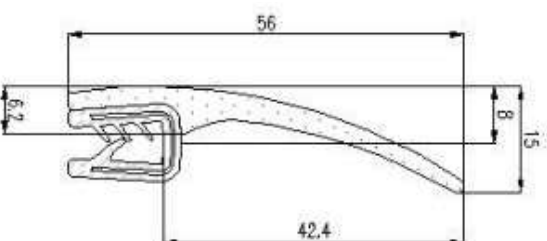

EPDM 0.60 GR/CM³

E-396-P

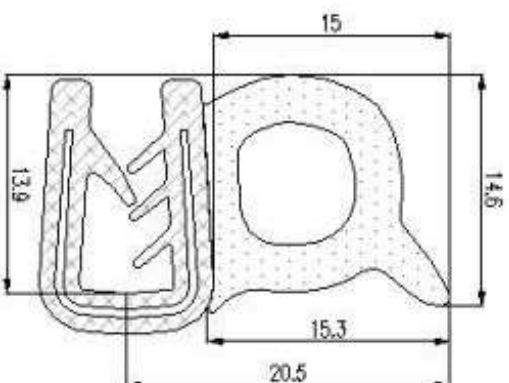

EPDM 0.50 GR/CM³

E-402-P

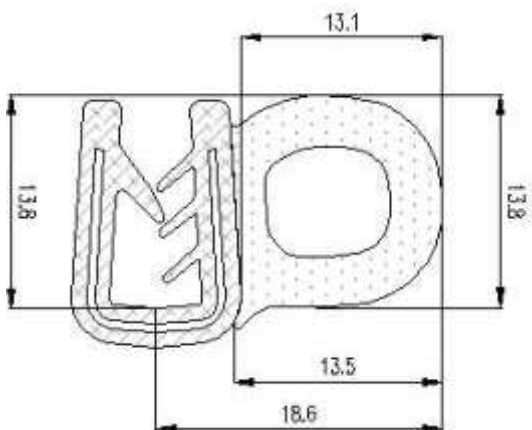

EPDM 0.60 GR/CM³

E-404-P

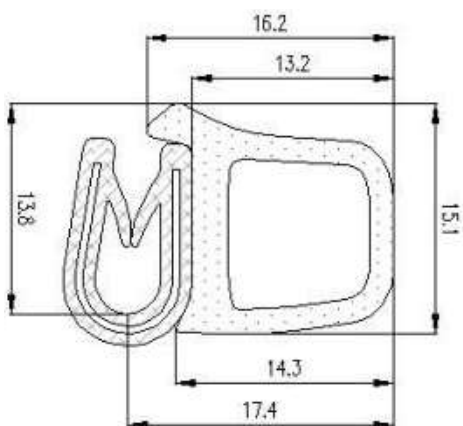

EPDM 0.50 GR/CM³

E-406-P

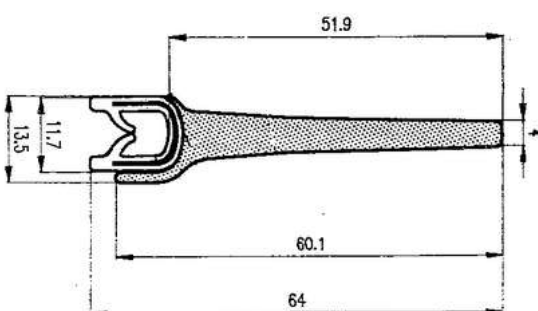

EPDM 0.60 GR/CM³



E-408-P

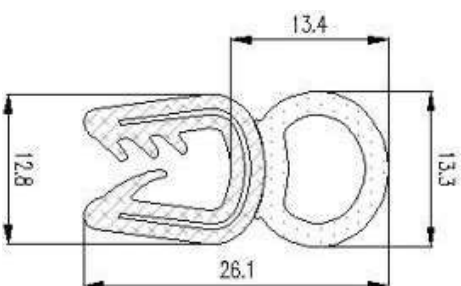

EPDM 0.60 GR/CM³

E-409-P

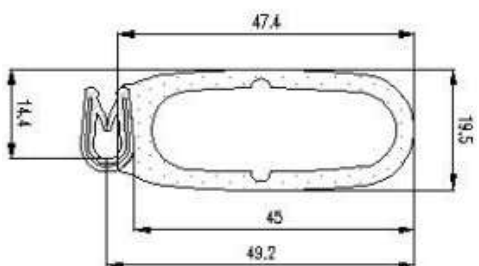

EPDM 0.60 GR/CM³

E-415-P

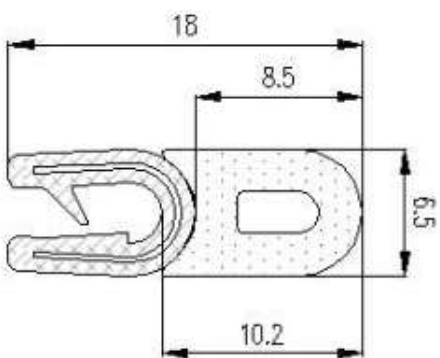

EPDM 0.60 GR/CM³

E-418-P

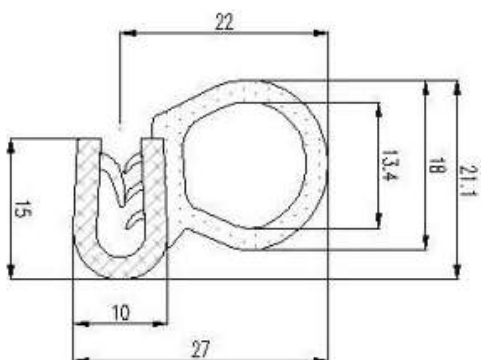

EPDM 0.60 GR/CM³

E-420-P

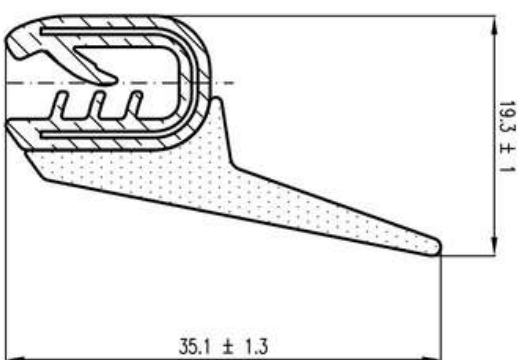

EPDM 0.60 GR/CM³

E-421-P

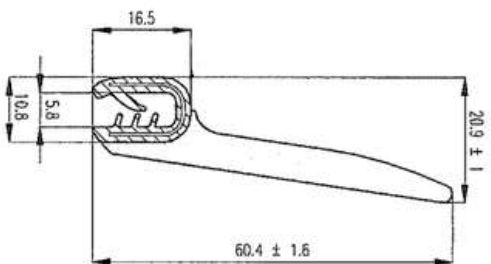

EPDM 0.50 GR/CM³

E-423-P

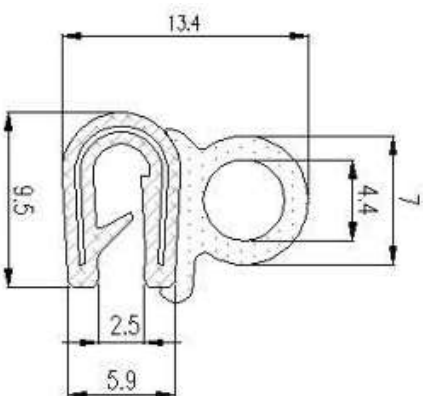

EPDM 0.60 GR/CM³

E-425-P

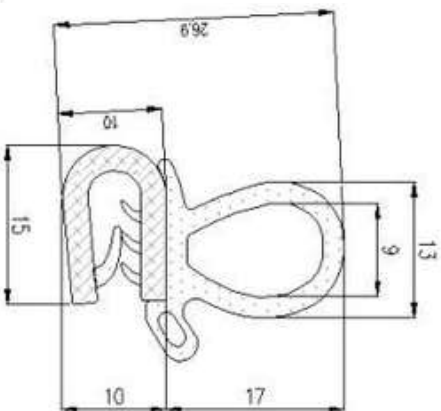

EPDM 0.60 GR/CM³

E-427-P

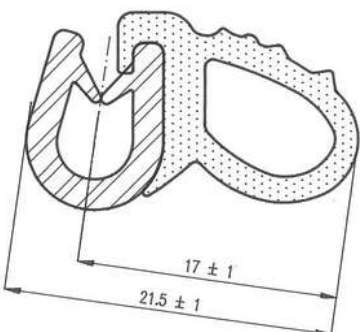

EPDM 0.60 GR/CM³

E-438-P

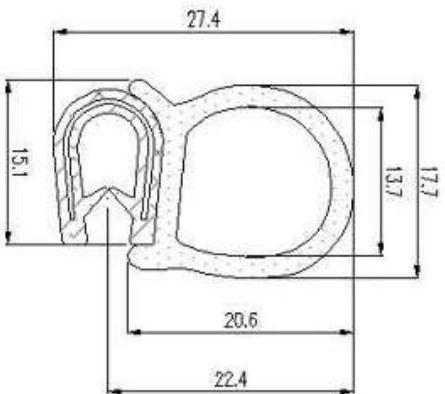

EPDM 0.60 GR/CM³

E-441-P

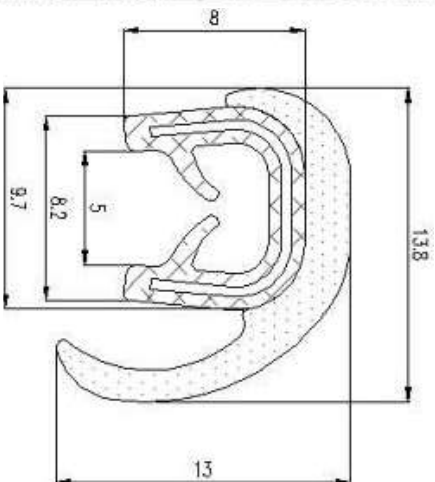

EPDM 0.50 GR/CM³

E-443-P

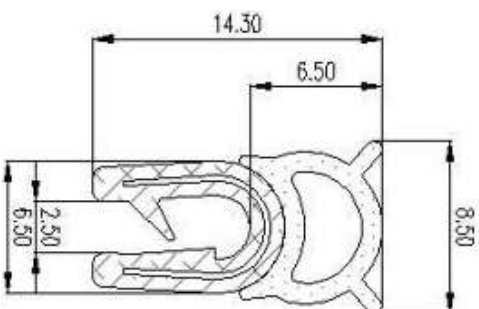

EPDM 0.60 GR/CM³

E-456-P

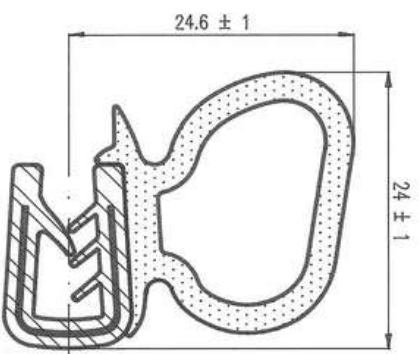

EPDM 0.60 GR/CM³

E-458-P

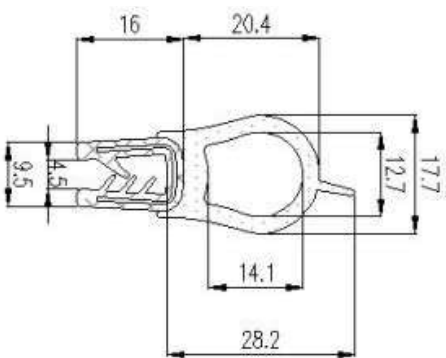

EPDM 0.60 GR/CM³

E-463-P

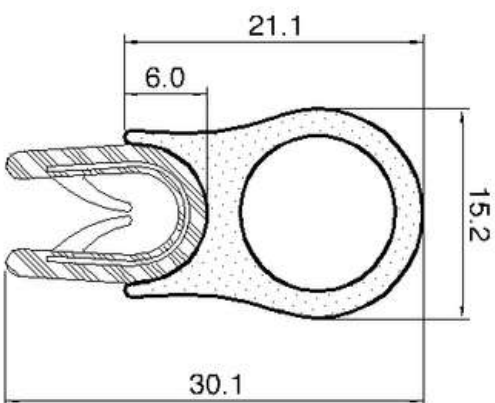

EPDM 0.60 GR/CM³

E-465-P

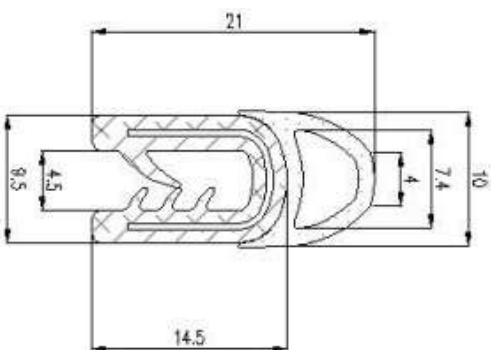

EPDM 0.60 GR/CM³

E-469-P

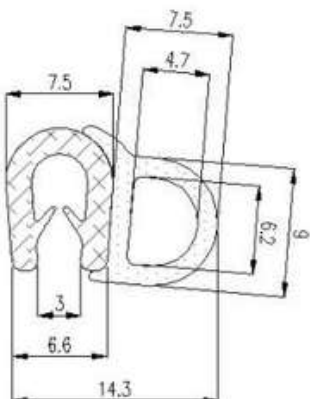

EPDM 0.50 GR/CM³

E-470-P

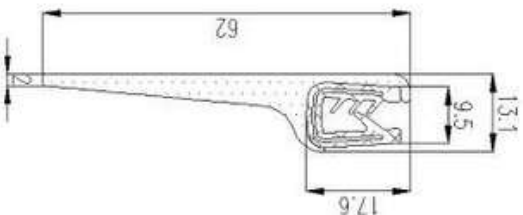

EPDM 0.60 GR/CM³

E-475-P

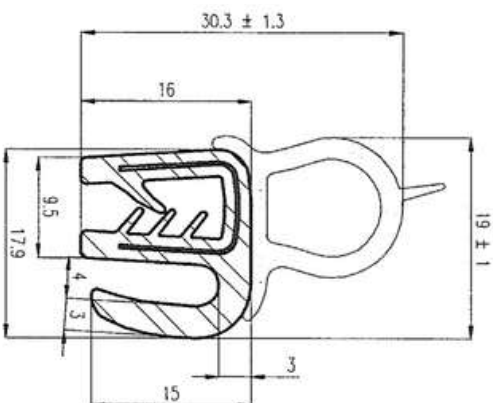

EPDM 0.60 GR/CM³

E-482-P

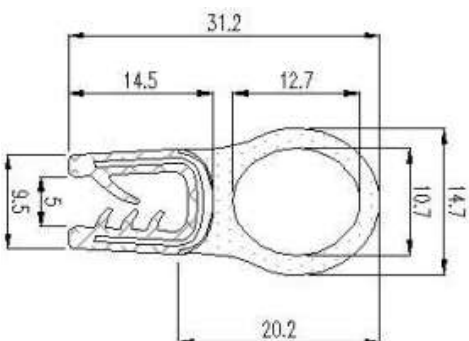

EPDM 0.60 GR/CM³

E-487-P

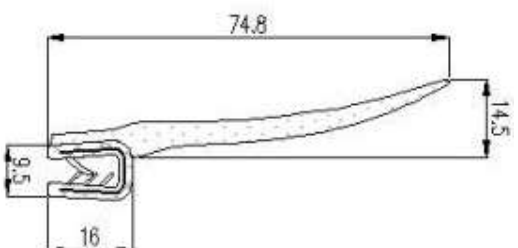

EPDM 0.60 GR/CM³

E-489-P

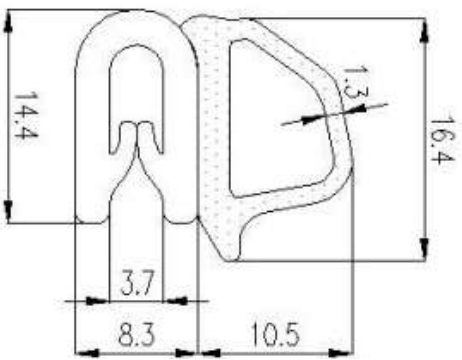

EPDM 0.60 GR/CM³

E-531-P

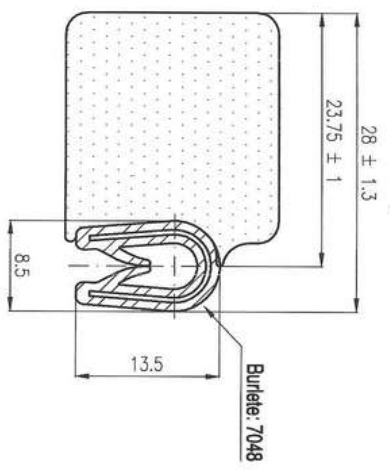

CR 0.60 GR/CM³

E-512-P

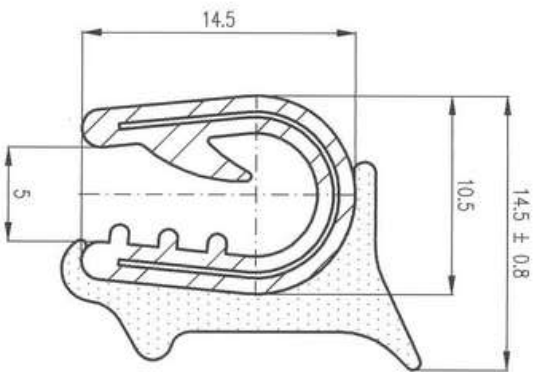

EPDM 0.60 GR/CM³

E-535-P

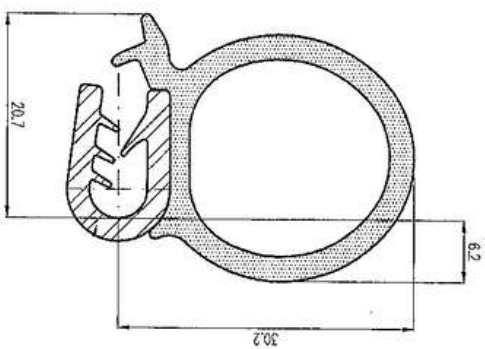

EPDM 0.60 GR/CM³

E-519-P

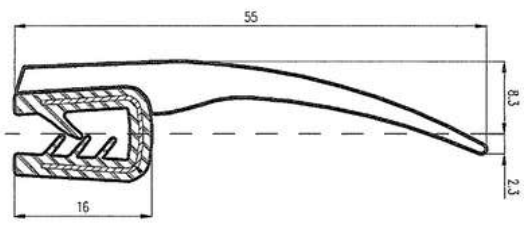

EPDM 0.60 GR/CM³

E-562-P

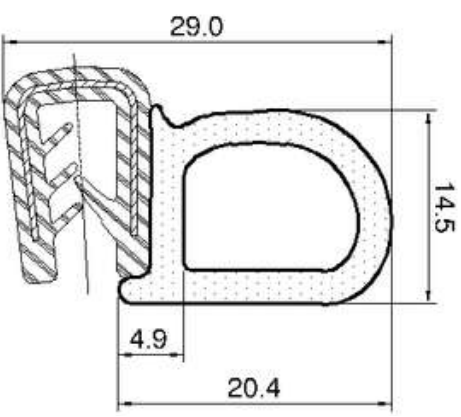

EPDM 0.60 GR/CM³



E-522-P

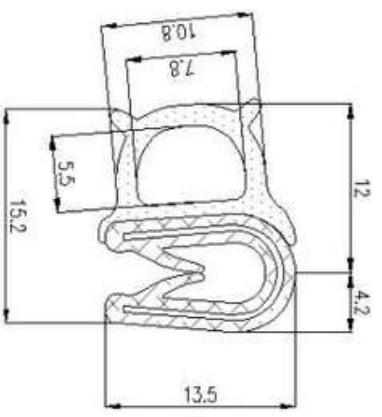

EPDM 0.60 GR/CM³

E-572-P

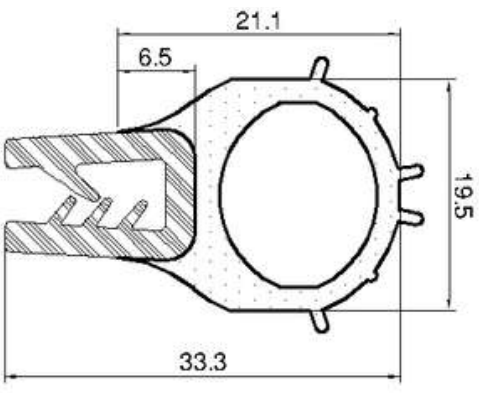

EPDM 0.60 GR/CM³

E-575-P

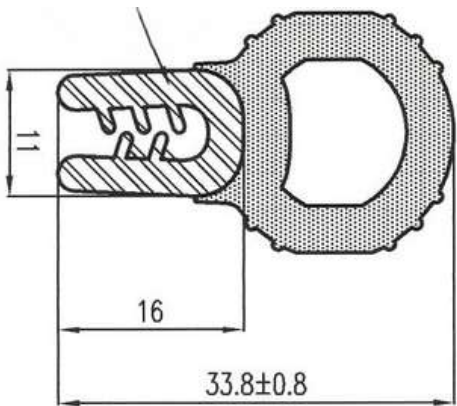

EPDM 0.60 GR/CM³

E-657-P

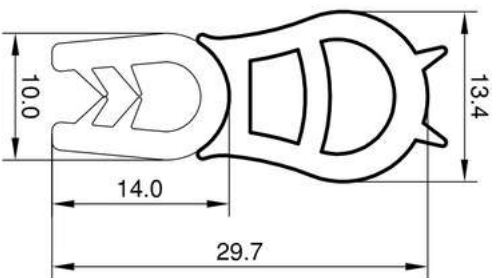

EPDM 0.60 GR/CM³

E-696-P

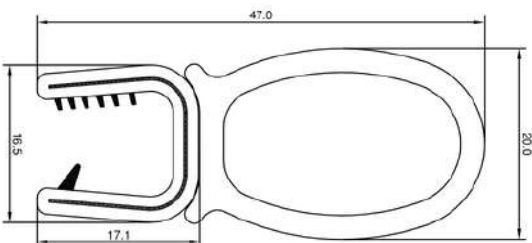

EPDM 0.60 GR/CM³



RIALS

INDUSTRIAS TÉCNICAS S.L.

PÁGINA 9

E-704-P

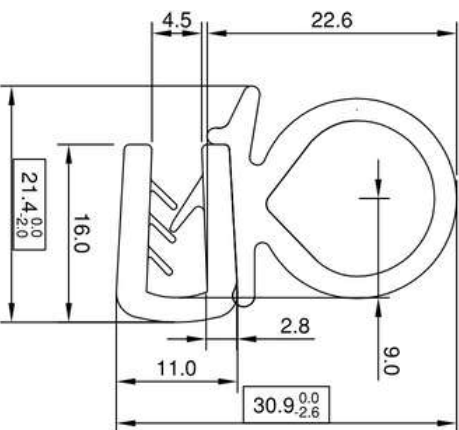

EPDM 0.85 GR/CM³

PLA-011

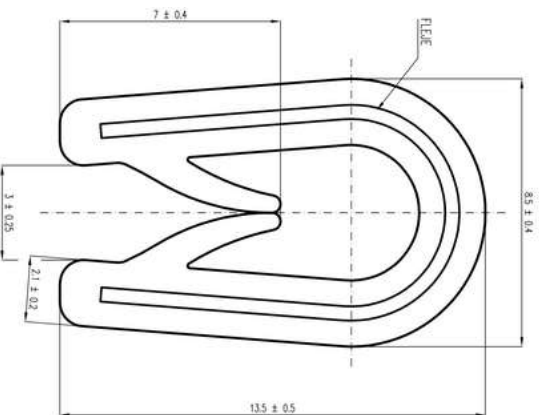

PVC 70º Sh.A

PLA-012

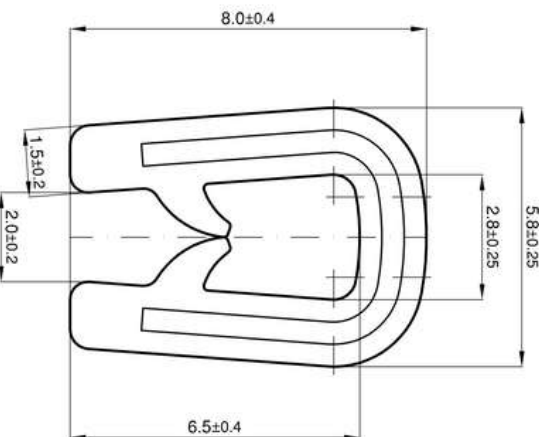

PVC 78º Sh.A

PLA-013

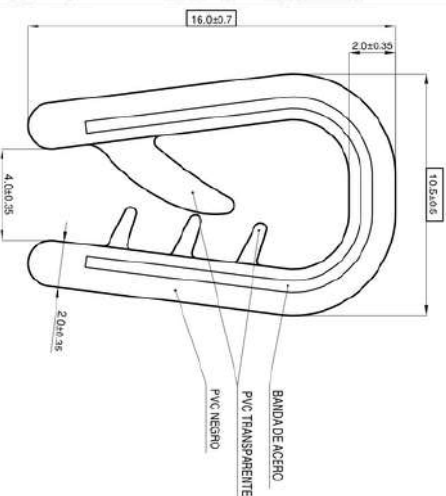

PVC 79º Sh.A

**PARA OTRAS
GEOMETRÍAS ESCRIBIR A**

COMERCIAL@RIALS.ES

**CALLE PRIMAVERA 9, PARQUE
INDUSTRIAL “LAS MONJAS”, TORREJÓN
DE ARDOZ, 28850, COMUNIDAD DE
MADRID, ESPAÑA**

PUEDES SECUIRNOS EN



Rials Extrusión Técnica S.L.

[MUCHO MÁS EN WWW.RIALS.ES](http://WWW.RIALS.ES)

(Telf) +34 91 677 06 85

(FAX) +34 91 678 11 49